

N°	Code	Description	Qty
1	12-01114	FLUE HOOD	1
2	15-00843	ROOM-SEALED CHAMBER BOTTOM LEFT DEFLECTOR	1
3	15-00844	ROOM-SEALED CHAMBER BOTTOM RIGHT DEFLECTOR	1
4	28570LP	ROOM SEALED CHAMBER COVER	1
5	28694LP	ROOM-SEALED CHAMBER BACK SIDE	1
6	30045LP	COMBUSTION CHAMBER BACK PANEL-BOTTOM SECTION	1
7	30047LP	COMBUSTION CHAMBER RIGH SIDE PANEL RSF24/30	1
8	30048LP	COMBUSTION CHAMBER LEFT SIDE PANEL RSF24/30	1
9	30052LP	COMBUSTION CHAMBER BACK PANEL-TOP SECTION	1
10	30054LP	COMBUSTION CHAMBER FRONT PANELRSF 30 2003	1
11	35-00173	CASING FRONT PANEL	1
12	40047LP	EXHAUST FAN D.85 FLANGE	1
13	43137LA	SYLICON WASHER W/INSPECTION WINDOW Ø35	1
14	43147LA	CERAMIC FIBRE FRONT 295x210x10	1
15	43148LA	CERAMIC FIBRE BACK 317x210x10	1
16	43149LA	CERAMIC FIBRE RIGHT/LEFT SIDE198x185x7.5SP	2
17	52058LA	WHITE CASE ANGLE BAR	2
18	52131LA	CASING RIGHT SIDE PANEL	1
19	52132LA	CASING LEFT SIDE PANEL	1
20	52134LA	CASING FRONT UPPER DOOR RBA100 SLIM - RA0303	1
21	52135LA	CASING COVER RBA 100 SLIM	1
22	52136LA	CASING BACK SIDE UPPER PANEL	1
23	52137LA	CASING BACK SIDE LOWER PANELRBA100 SLIM - RA0306	1
24	52138LA	BASE RBA 100 SLIM RA 0307	1
25	52139LA	BASE BRACKET	2
26	52140LA	FRAME SUPPORT FRONT/RIGHT SIDE	1
27	52141LA	FRAME SUPPORT FRONT/LEFT SIDERBA 100 SLIM -RA0310	1
28	52142LA	FRAME SUPPORT BACK/RIGHT SIDERBA 100 SLIM -RA0311	1
29	52143LA	FRAME SUPPORT BACK/LEFT SIDERBA 100 SLIM -RA0312	1
30	52144LA	FRAME BRACKET FRONT/BACK SIDE	2
31	52145LA	FRAME BRACKET LEFT/RIGHT SIDER	2
32	52146LA	FRONT CASE MIDDLE DOOR RBA 100	1
33	62011LP	HOLES CLOSING PLATE Ø100	2
34	74234LP	EXPANSION VESSEL BOTTOM BRACKET	1
35	74475LP	FIXING BOILER BRACKETRBA/RKA 100	1
36	74531LP	BOTTOM BOILER PLATE	1
37	79018LP	FRAME	1

Disegnatore	Rev.	data revisione	Autore revisione	Descrizione revisione
crislian.pozzaglini				
Modificato				
crislian.pozzaglini				
Data di creazione	Scala	Materiale	Sp.	Peso (Kg)
27/11/2018	1:115			6805.809
Note				
Descrizione completa PREMIUM MAX 32/100 MET RUS - RSA 32/100 TR R7				
Codice			Revisione	
G232A4121471			00	

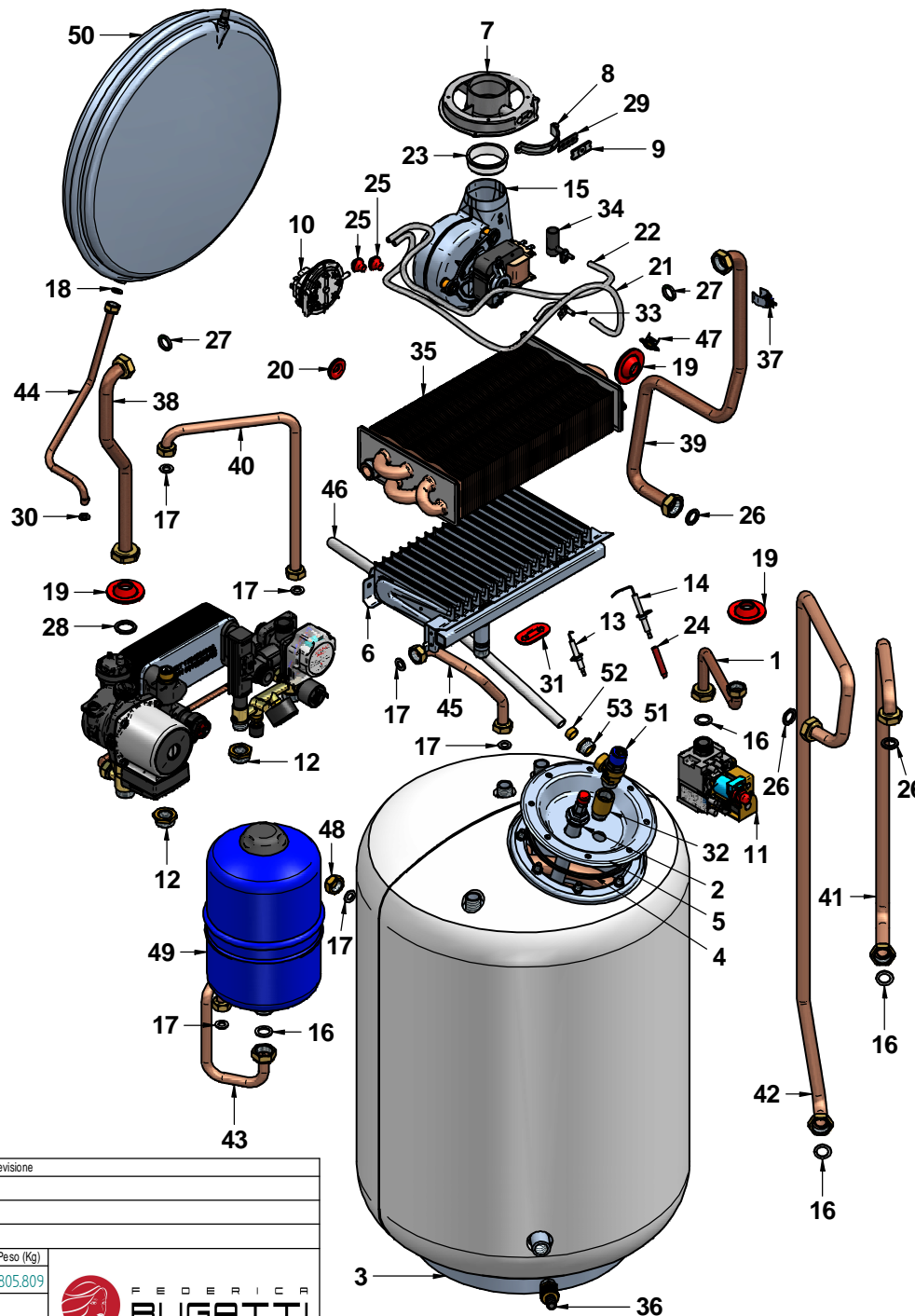



N°	Code	Description	Qty
1	12-01130	PIPE D.14 GAS VALVE	1
2	20025LA	MAGNESIUM ANODE W/SIMPLETEST VALVE x 25-45-100	1
3	20031LA	CYLINDER LT.100 RBA 100 SLIM	1
4	20034LA	WASHER FOR CYLINDER LT.25/45 FLANGE	1
5	20064LA	FLANGE w/ANODE+WASHER	1
6	21032LA	BURNER 17R.-1,20 NAT.GAS - 402.0054.04	1
7	27066LA	FLUE INSPECTION	1
8	27067LA	FIXING CLAMP FLUE INSPECTION	1
9	27068LA	PLATE FOR FLUE INSPECTION CLOSURE	1
10	30-00024	AIR PRESSURE SWITCH 3.28 - 2.98	1
11	30-00035	SIT GAS VALVE 845 113 230V	1
12	33026LA	HOT WATER OUTLET CONNECT. 3/4"	2
13	35007LA	IGNITION ELECTRODE E. 0774527	1
14	35009LA	IONISATION ELECTRODE EL.0774929	1
15	37016LA	EXHAUST FAN ES 30-108 G00-0416	1
16	43001LA	WASHER Ø 23.5x17x2 3/4" -AFM34	4
17	43002LA	WASHER Ø 18.5x10.2x2 1/2" -AFM34	6
18	43003LA	WASHER Ø15x8x2 3/8" -AFM34	1
19	43009LA	FB10/1 SYLICON RED WASHER ROUND TYPE	3
20	43010LA	FB11/1 SYLICON RED WASHER CONE TYPE	1
21	43018LA	SYLICON/TRANSPARENT PIPE Ø 8x4	1
22	43018LA	SYLICON/TRANSPARENT PIPE Ø 8x4	1
23	43031LA	EXHAUST FAN D.54 RUBBER COLLAR	1
24	43040LA	ELECTRODE RED RUBBER CAP 0619/36	1
25	43042LA	RED SYLICON WASHER FOR SYLICON PIPES D.8x4	2
26	43159LA	WASHER EPDM 80 SH M.PLEX 16x24x2,5 3/4"	3
27	43179LA	WASHER 23.5x17x3 3/4" AFM34	2
28	43208LA	WASHER 23x30x3sp EPDM 80sh 1"	1
29	43220LA	RUBBER WASHER EPDM FLUE INSPECTION	1
30	43258LA	O-RING 3037 EPDMDi.9,19	1
31	43352LA	FB12/1 SYLICON RED WASHER-OVAL	1
32	56036LA	1/2x30 x 96019 EXTENSION MF	1
33	57501LP	AIR PRESSURE POINT D.6	1
34	57525LA	VENTURI NEGATIVE PRESSURE POINT 2008	1
35	58025LP	HEAT EXCHANGER 30K06 3S	1
36	67003LA	DRAIN VALVE RSC/G 1/2"	1
37	73516LA	HTG CLIP SENSOR X PIPE 17/18mm BLUE	1
38	83012LP	PIPE D.18 HEAT EXCHANGER-PUMP	1
39	83328LP	PIPE D.18 MAIN H.EXCH.3WAY VALVE	1
40	83455LP	PIPE D.14 COLD WATER RBA 100	1
41	83457LP	PIPE D.18 CYLINDER/3 WAY VALVERBA 100	1
42	83458LP	PIPE D.18CYL./FLOWSWITCH GROUP RBA 100	1
43	83645LP	PIPE D.14 DHW 5LT. EXP.VESSEL	1
44	83708LP	PIPE D.10 EXPANSION VESSEL	1
45	83732LP	PIPE D.14 HOT WATERRBA100/RKA100 NM	1
46	84199LA	PIPE POL.15X1,8	1
47	86006LA	SAFETY THERMOSTAT 95gr(ø)E.	1
48	89023LA	BRASS CAP 1/2" E. 24	1
49	95007LA	EXPANSION VESSEL LT.5	1
50	95018LA	EXPANSION VESSEL LT.10 RS/RSF30	1
51	96019LA	SAFETY VALVE 1/2" 8ATM	1
52	96028LA	SAFETY VALVE BICONE D.15	1
53	96029LA	NIPPLE 1/2" M/F FOR SAF. VALVE BICONE	1

Disegnatore	Rev.	data revisione	Autore revisione	Descrizione revisione
cristian.pazzaglini				
Modificato				
cristian.pazzaglini				
Data di creazione	Scala	Materiale	Sp.	Peso (Kg)
27/11/2018	17			5805.809
Note				
Descrizione completa				
PREMIUM MAX 32/100 MET				
RUS - RSA 32/100 TR R7				
Codice		Revisione		
G232A412I471		00		



OGNI TUBO IN PIASTRE NON SONO IMPIEGABILI. LA BUSTA DI RISERVA È DOTATA DI CARATTERI IMMOBILIZZANTI. I CARATTERI DI PREVENZIONE DI DILATAZIONE SONO NECESSARI PER GARANTIRE IL CORRETTO FUNZIONAMENTO. CONTINUTI NEL PRESENTE OPUSCOLO SE DEVUTE AL TERZO O DI TRASMISSIONE. TUTTI I DIRITTI SONO RISERVATI. NESSUNA PARTE DI QUESTO DOCUMENTO PUÒ ESSERE RIPRODOTTA, RENDICAZIONE IN SISTEMI DI ARCHIVIO O TRAMANDA. IN QUALSIASI FORMA IN TUTTI I SETTORI TECNICI, NECESSARIA L'OTTEZIONE DI AUTORE. PRESENTAZIONE, MODIFICAZIONE, DELLA BUSTA.

N°	Code	Description	Qty
1	40-00107	FRAME-PRINTED CIRCUIT BOARD CABLE	1
2	40-00299	LINK JUMPER CABLE	1
3	40-00302	PRINTED CIRCUIT BOARD	1
4	40-00368	HTG / DHW / MODULATOR SENSOR CABLE	1
5	40-00378	DIVERTER VALVE CABLE	1
6	40-00469	POWER SUPPLY/CIRC.PUMP/FAN/GAS VALVE CABLE	1
7	40-00470	SAFETY THERM.CABLE/AIR PRESS.SWITCH/FLOWSWITCH	1
8	45-00008	RUBBER BUTTON "+/-"	3
9	45-00031	CONTROL PANEL R5	1
10	45-00033	CONTROL PANEL BACK PLATE	1
11	45-00051	CONTROL PANEL TERMINAL FIXING CLAMP - R5	2
12	45-00061	CONTROL PANEL FRONT COVER	1

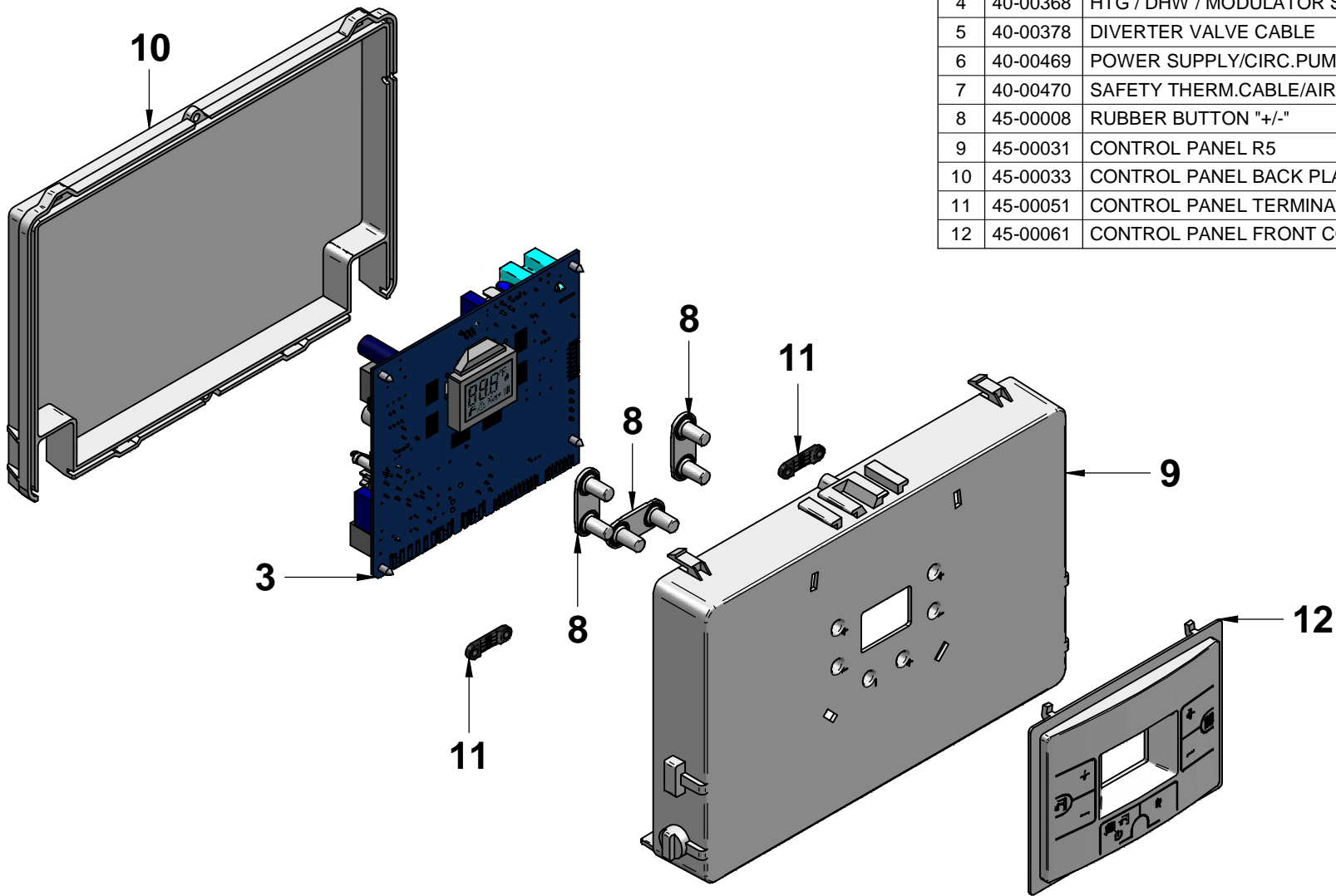

Disegnatore	Rev.	data revisione	Autore revisione	Descrizione revisione
cristian.pazzaglini				
Modificato				
cristian.pazzaglini				
Data di creazione	Scala	Materiale	Sp.	Peso (Kg)
29/11/2018	12			342,258
Note				
Descrizione completa CONTROL PANEL COMPLETE RSA 28-32/100 - R7				
Codice				Revisione
41-00315				00

